

# SERVICE LETTER SL55 65-17110

1. **Release Date:** 05/07/2022
2. **Service Letter No.:** SL55-65-17110
3. **Subject:** Bulkhead Reinforcement for Existing Floats
4. **Part/Assembly No.:** 65-17110 (6650) 65-21110 (6750)
5. **Float Models Affected:** 6650 and 6750
6. **Compliance:**  **Mandatory**  **Recommended**  **Optional**
7. **Approval:** All information provided is in accordance with approved data.
8. **Corrective Action:** Non-required.
9. **Estimated Time Required:** 3.5 hours
- 10 **Payments:**  Credit to Customer  Under Warranty  Customer Pays

Aerocet has introduced optional reinforcements which may be installed as shown in the diagram below and may be applied without the removal of any bonded float components.

Configuration 65-17110-2 (6650) and 65-21110-2 (6750) both use 65-17111 and 65-17113 Cross-Float Reinforcements, which can be installed in any float constructed before Revision G of 65-17110 Bulkhead Installation. It is intended for retrofit installation.

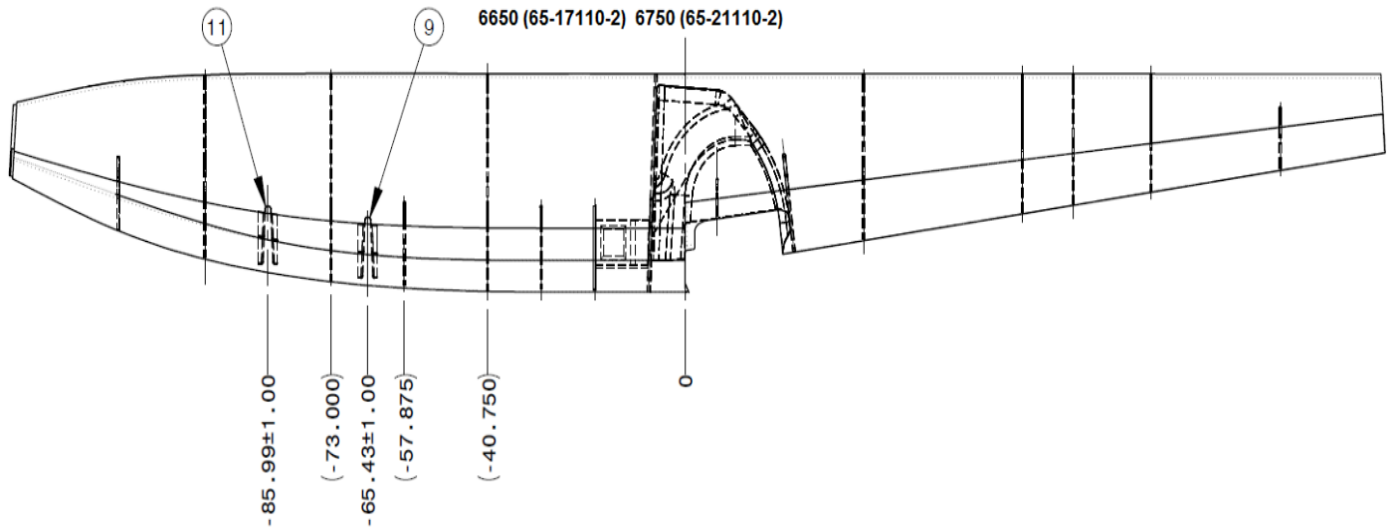

65-17113 SHOWN  
65-17111 SIMILAR

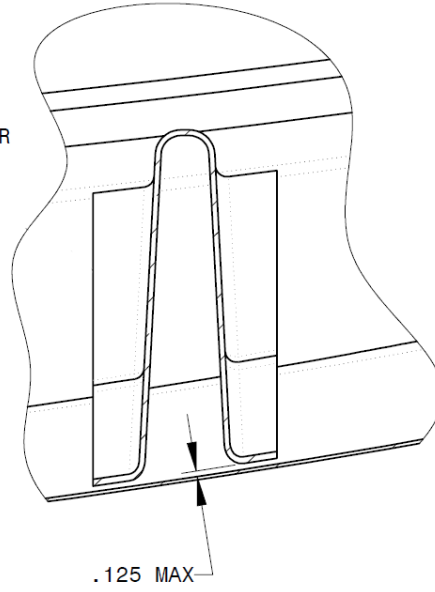

PARTS LIST - CROSS-FLOAT REINFORCEMENTS				
ITEM NO.	QTY	TYPE	PART NUMBER	DESCRIPTION
9	1	PART	65-17111	CROSS-FLOAT REINFORCEMENT, STA. -65.43
11	1	PART	65-17113	CROSS-FLOAT REINFORCEMENT, STA. -85.99

CONTACT AEROCET FOR PARTS, INSTALLATION, AND PRICE.

-END-