

SERVICE LETTER SL44 66-12107 Rev A

1. **Release Date:** 08/30/2018
2. **Service Letter No.:** SL44 66-12107
3. **Reason for Change:** Tolerance stacking between the Aircraft and the float installation parts is causing an installation difficulty.
4. **Part/Assembly No.:** 66-12107
5. **Float Model Affected:** 6650 and 6750
6. **Disposition of Product in Field:** NA
7. **Approval:** All information provided is in accordance with approved data.
8. **Corrective Action:** Informational Only (See additional verbiage below)
9. **Time Required:** NA
10. **Payments to customer:** None. Call (208) 448-0400 for Parts Department

NOTE:

66-12107 SPACER, FWD FUSELAGE FITTING, AEROCET MODEL 6650 FLOAT INSTALLATION, KODIAK AIRCRAFT

Purpose:

To accommodate the tolerance of the engine mount, Aerocet redesigned the 66-12107 spacer, ultimately manufacturing them in three different outside dimension sizes. The -1 is the smaller of the spacers and the -3 is the largest.

Existing parts in the field that were previously installed can still be used *as long as they do not conflict with the engine mounts and pass a visual inspection for excessive wear and damage.*

66-12107 Installation:

The installer or mechanic is to use the largest dash number (66-12107-1 through -3) that will fit inside the engine mounts.

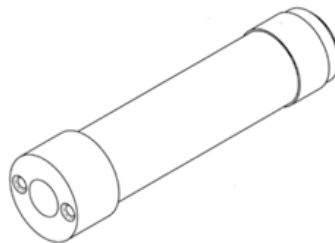

66-12107 ISOMETRIC VIEW

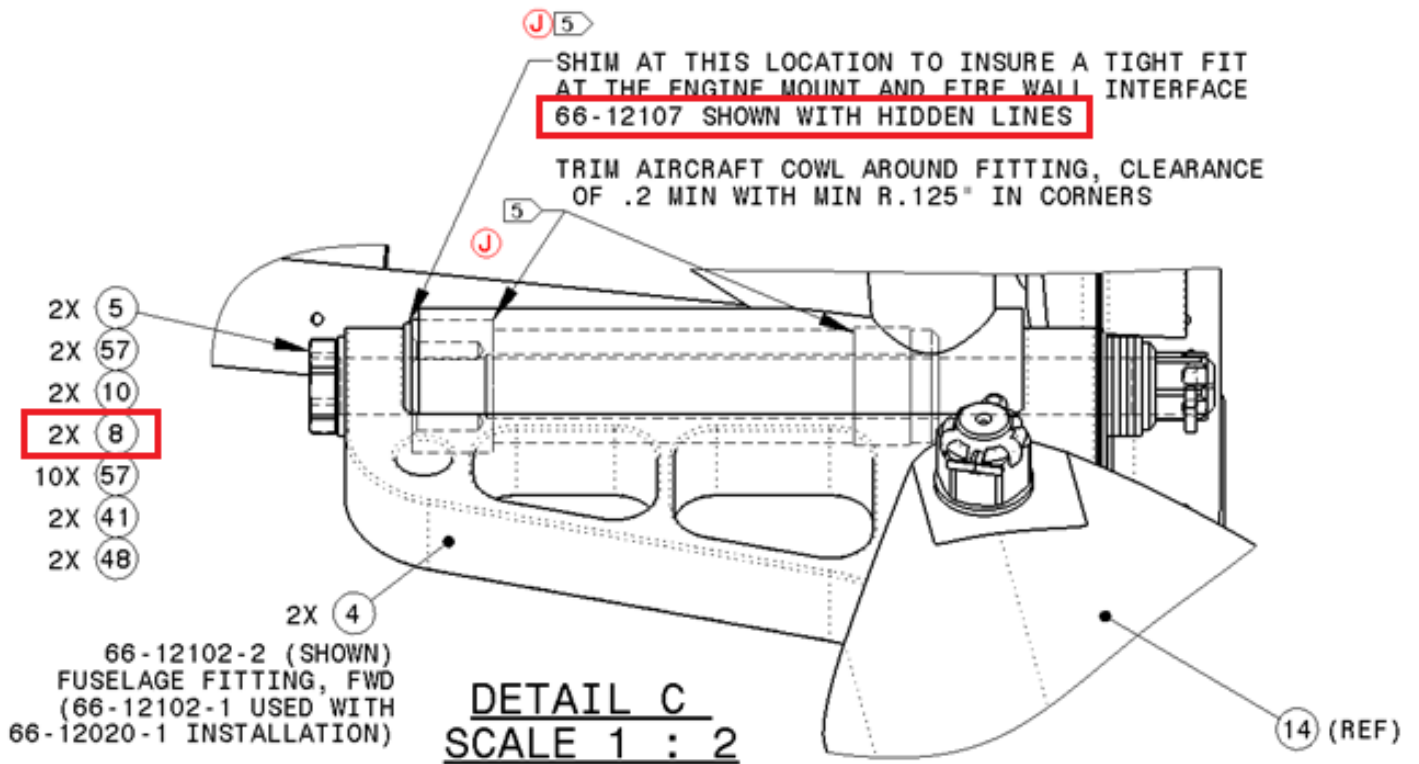

Parts Kit

| Item No. | Qty | | | Type | Part Number | Description |
|----------|-----|----|----|------|-------------|------------------------------|
| | -1 | -2 | -3 | | | |
| 8 | 2 | 2 | 2 | PART | 66-12107 | SPACER, FWD FUSELAGE FITTING |

| Rev | Date | Summary of change | Authorized by |
|-----|------------|---|---------------|
| I/R | 08/22/2018 | Initial Release | LM |
| A | 08/30/2018 | Added additional verbiage "Existing parts in the field that were previously installed can still be used as long as they do not conflict with the engine mounts, and pass a visual inspection for excessive wear and damage." for clarification. | LM |