



# SERVICE LETTER SL40 66-12127

1. **Release Date:** 02/01/2018
2. **Service Letter No.:** SL40 66-12127 Rev I/R
3. **Subject:** New eyebolt
4. **Part/Assembly No.:** 66-12127
5. **Float Model Affected:** 6650 and 6750
6. **Compliance:**  **Mandatory**  **Recommended**  **Optional**
7. **Approval:** All information provided is in accordance with approved data.
8. **Corrective Action:** Non-required.
9. **Time Required:** 3 to 3.5 hours
10. **Payments:**  Credit to Customer  Under Warranty  Customer Pays

**Notes:**

Refer to A-10038 Rev 2 or later for additional information, such as corrosion protection, hoisting and jacking, and torque values for fasteners.

1. Hoist airplane and secure as necessary.
2. Support floats.
3. Loosen and remove forward tie rods.
4. Remove AN48-24 eyebolts (upper Strut) and replace with Aerocet part 66-12127 eyebolts.
5. 66-12191 Tie Rods must be trimmed in accordance with 66-12020 (6650 floats), or 66-11020 (6750 Floats), Sheet 2. This assures clearance to new eyebolt when installed and tensioned.
  - a. Alternatively, 66-12188, a shorter tie rod may be available in the future, which is produced at the desired length. (Contact Aerocet for details.)
  - b. Before trimming, install a check nut, such as AN315-7R or L, ("R" is for right hand threads; "L" is for left hand threads and one of each is necessary for each tie rod being trimmed). Use and maintain anti-seize lubricant such as Loctite Marine Grade Anti-Seize 8023 on tie rod threads. The nut will then help to deburr and re-form any lightly damaged threads when removed after trimming the tie rods. It is not recommended to reuse these nuts as they may themselves sustain thread damage. (Stainless, threaded materials commonly gall if lubricant is not maintained.)
  - c. Typical methods for trimming the tie rods includes use of a cutoff wheel or a grinding wheel. Once the length trim is completed, use a grinding wheel to add a chamfer to the end of the threads. This is intended to remove sharp edges, thin, razor threads that might otherwise mal-form and cause threaded nuts or clevis ends to seize. This chamfer should be approximately 1/16" x 45°, or to the depth of the minor thread diameter.
  - d. Clean the threads thoroughly and completely with a solvent and apply a new amount of anti-seize.

- e. Remove the previously installed nut, sensing any restrictions as you do so. It is recommended that anti-seize be reapplied often if necessary, and the nut be run across the trimmed ends until it runs freely.
  - f. Clean the tie rod ends of all debris, using solvent if necessary. Reapply anti-seize.
  - g. Reinstall original or new tie rod hardware.
6. Inspect fasteners and tie rods for any damage or corrosion.
  7. Apply EZ-TURN Lubricant by United Erie, (readily available through common aviation supply outlets) or equivalent to all fasteners during and after installation to inhibit corrosion.
  - 8.

**NOTE:**

Aerocet Maintenance Manual, A-10038 Rev 2, contains an expanded Section 13 regarding corrosion prevention and anti-corrosion compounds. Aerocet recommends a review of this and developing a regimen that suits the environment in which the aircraft works. (See also Section 17 for inspections and product listings.)

9. 66-12127 Eyebolt is to be oriented with the leaf, or ear aligned parallel to the installed tie rod, so that the tension on the tie rod is in line is at its straightest and shortest length.

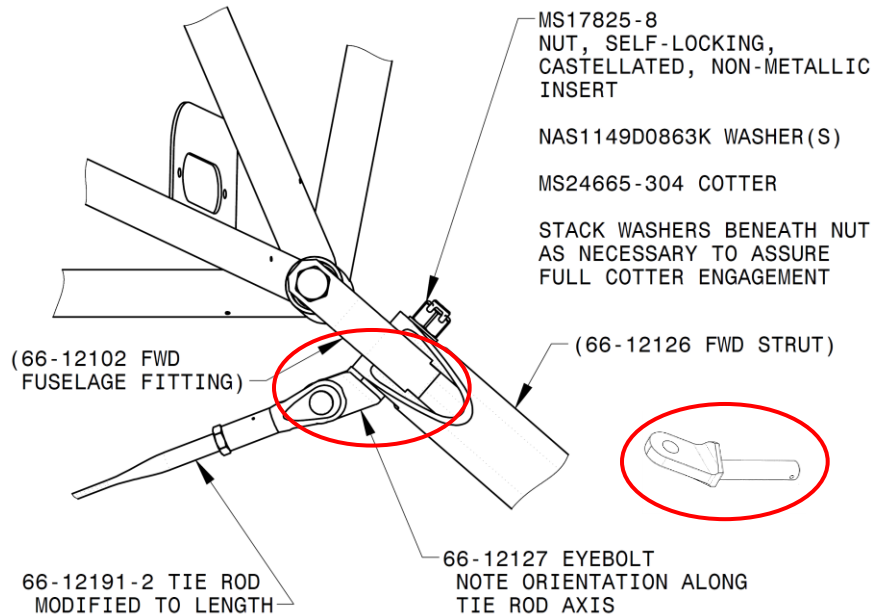

VIEW FROM FRONT OF AIRCRAFT  
SHOWING FWD STRUT AND FITTING INSTALLATION  
FUSELAGE SKIN HIDDEN FOR CLARITY

10. Fastener torque in accordance with A-10038, Section 1.4.
11. Adjust tie rods and rig installation in accordance with either 66-12020 Rev G or later, or 66-11020, Rev C or later.

Parts List				
Item No.	Quantity	Type	Part No.	Description
1	2	PART	66-12127	EYEBOLT
2	4	HRDWR	NAS1149D0863K	WASHER, FLAT
3	2	HRDWR	MS17825-8	NUT, SELF-LOCKING, CASTELLATED
4	2	HRDWR	MS24665-304	COTTER
Do not use in flight—disposable for this service letter only.				
5	2	HRDWR	AN315-7L	Jam nut
6	2	HRDWR	AN315-7R	Jam nut
Drawings to be Included				
66-12020 Rev G or later (all pages)				
66-11020 Rev C or later (all pages)				

Product Listings:

1. EZ-TURN Lubricant by United Erie, or similar.
2. Loctite 8023 Marine Grade Anti-Seize lubricant (for threads and pins of tie rods) or similar.

-See A-10038, Section 17.8 for additional recommended Product Listings

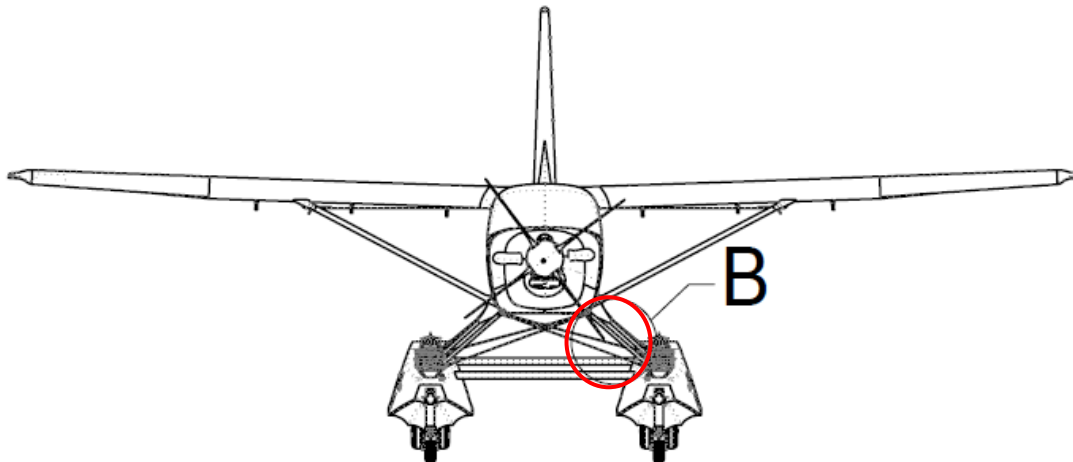

Rev	Date	Summary of Change	Authorized by
I/R	02/01/2018	Initial Release	LM

-END-