

SERVICE LETTER SL33 66-12200 Rev C

1. **Release Date:** 05/22/2018
2. **Service Letter No.:** SL33 66-12200
3. **Reason for Change:** Alternate installation of water rudder retract handle allows for additional throw and adjustability to water rudder retract handle with use of a pulley and different anchor point for the retract cable.
4. **Part/Assembly No.:** 66-12200, 66-12201, 66-12202
5. **Float Model Affected:** 6650 with pedestals @REV H and earlier
6. **Disposition of Product in Field:** Optional
7. **Approval:** All information provided is in accordance with approved data.
8. **Corrective Action:** NA
9. **Time Required:** 1 Hour
10. **Payments to Customer:** None. Call (208) 448-0400 for Parts Department

Notes:

1. Water rudder retract handle, (alternate installation (shown) is intended to provide installers and operators a means of additional adjustment to water rudders
2. This drawing covers only the portions of the installation relevant to the alternate method. All water rudder rigging requirements shall be in accordance with 66-12200 water rudder rigging.
3. By use of the pulley and anchor system shown, the throw of the of the retract handle is increased, which will result in a water rudder that is higher when in the retracted position than it would be without.
 - a. Larger adjustments must first be done in the context of the 66-12200 rigging installation drawing.
 - b. Finer, incremental adjustments can be accomplished by the choice of fastener hole in 66-47403 arm.
 - c. NOTE: Holes that are the farthest from the retract arm pivot will have the most throw, while holes that are closest will have the least throw.
4. Water rudder shall reach full extended (deployed condition when arm is in the full, forward position, in accordance with drawing number 66-12200.
5. Assure free travel of retract handle, pulley and cable.

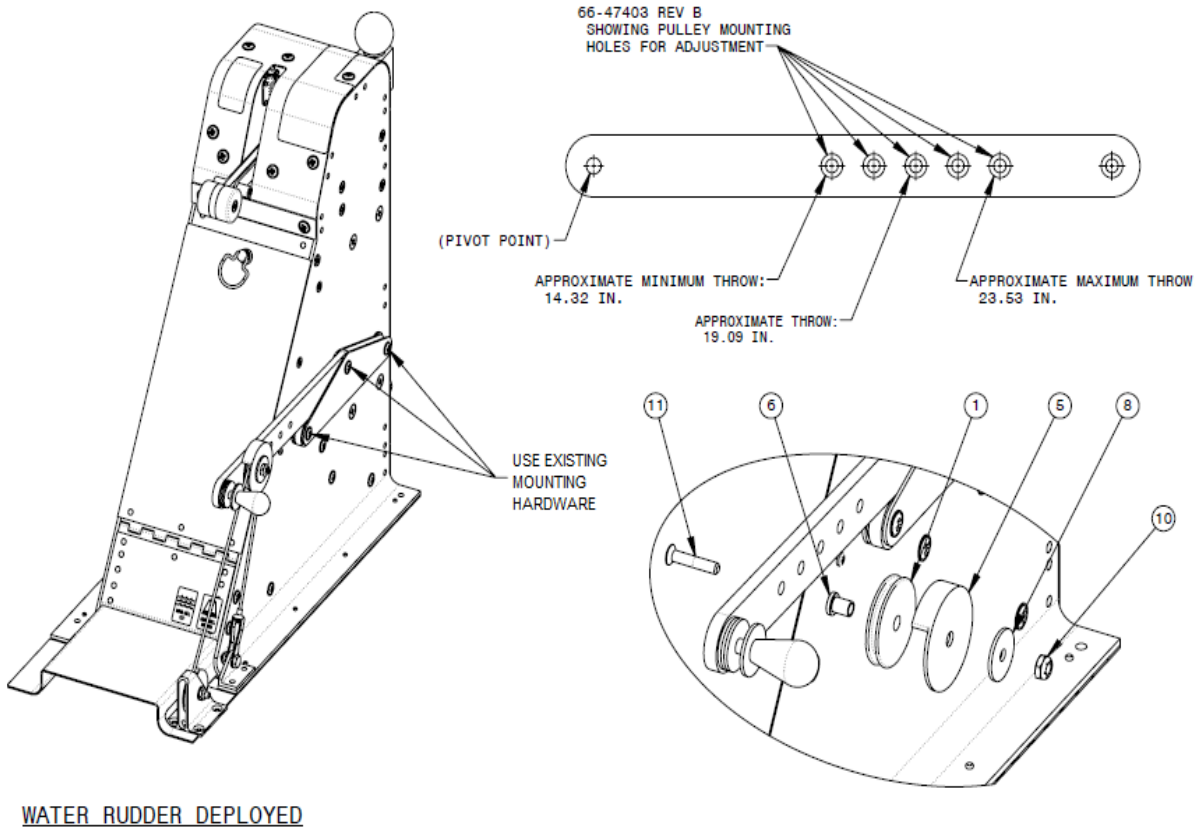
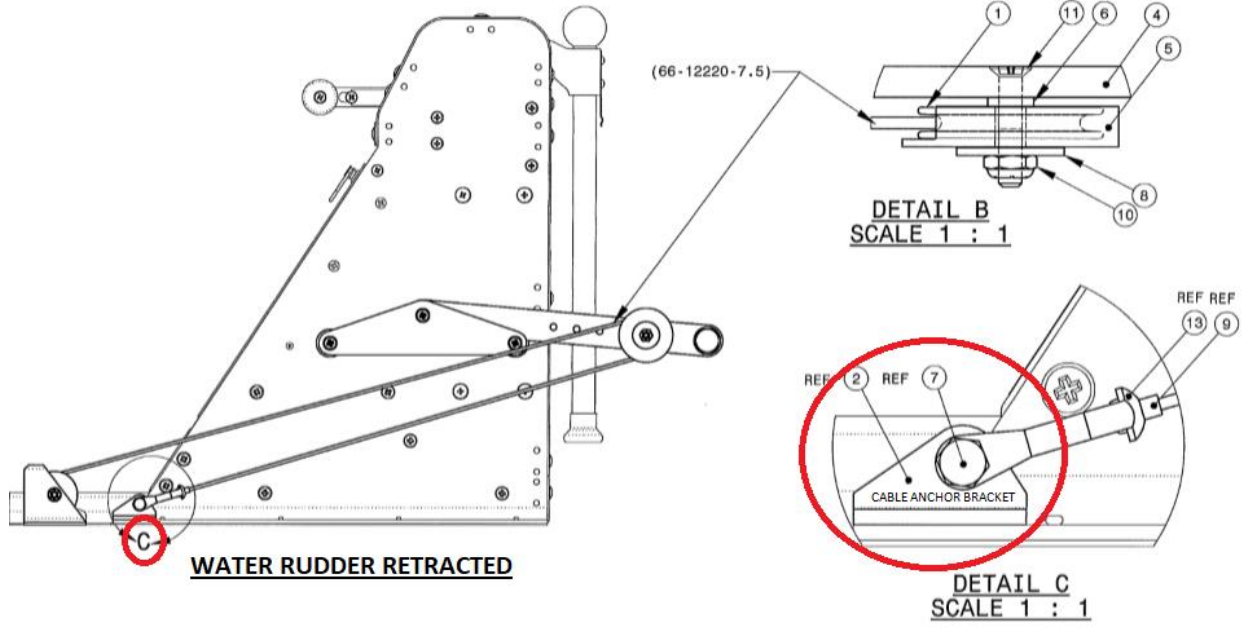

Part Kit

Item No.	Qty	TYPE	PART NUMBER	DESCRIPTION
1	1	PART	35-34030	PULLEY
2	1	PART	66-12202	BRACKET, CABLE ANCHOR
3	1	PART	35-34047	PULLY ASSEMBLY
4	1	ASSY	66-47403	RETRACT HANDLE
5	1	PART	66-47404	CABLE GUARD
6	1	PART	66-47405	CABLE GUARD BUSHING
8	1	HRDWR	AN970-3	WASHER, FLAT (LARGE AREA)
10	2	HRDWR	MS21083C3	NUT, SELF-LOCKING, LOW HEIGHT, STAINLESS
11	1	HRDWR	MS24694S58	MACHINE SCREW, FLAT COUNTERSUNK HEAD, 100°
29	1	HRDWR	AN3-5	BOLT, MACHINE, AIRCRAFT
32	1	HRDWR	AN310-3	NUT, PLAIN, CASTELLATED, AIRFRAME
45	1	HRDWR	MS24665-151	COTTER PIN
49	1	HRDWR	NAS1149C0316R	WASHER, FLAT STAINLESS
50	1	HRDWR	NAS1149C0363R	WASHER, FLAT STAINLESS
NN1	1	HRDWR	AN525-10R14	MACHINE SCREW (ONE EXISTING)
NN2	1	HRDWR	MS21059L3	DRY FILMED COUNTERSUNK STEEL NUT, SELF LOCKING, PLATE (ONE EXISTING)
NN3	2	HRDWR	MS20470AD3-4	ALUMINUM UNIVERSAL HEAD RIVET, SOLID (2 EXISTING)
NN4	1	HRDWR	MS20664C3	BALL AND SINGLE SHANK
NN5	1	HRDWR	NAS1435K3	TERMINAL STRAP FORK END
NN6	1	ASSY	66-12220-7.5	CABLE, RUDDER RETRACT, COMMON

Note: Termination options are available in Drawing Number 66-12200. You can choose to order which parts you actually use beyond the scope of this parts kit.

Revisions

Rev	Date	Page	Summary of Change	Authorized by
I/R	08/16/2017	All	Initial issue	LM
A	08/17/2017	1	Added "with pedestals @REV H and earlier to line item #4	LM
		2	Added Detail C to drawing	
		3	Added additional items 3, 29, 32, 45, 49, and 50 to parts kit	
B	10/24/2017	3	Added additional items, NN1, NN2, NN3 TO PART KIT	LM
C	05/22/2018	3	Added following parts to kit: <ul style="list-style-type: none"> Item 2, Part 66-12202, (Cable Anchor Bracket) to Parts Kit Item NN4 HRDWR MS20664C3 Ball and Single Shank Item NN5 HRDWR NAS1435K3 Fork End. Item NN6 Part 66-12220-7.5 cable 	LM

-END-