

1. **Release Date:** 02/10/2017
2. **Service Letter No.:** SL24 66-12020
3. **Reason for Change:** Add repair bushings to be installed in accordance with Quest Aircraft Field Service Instruction (FSI) 143.
4. **Part/Assembly No.:** 66-12020, 66-12112, 66-12113
5. **Float Model Affected:** 6650
6. **Disposition of Product in Field:** NA
7. **Approval:** All information provided is in accordance with approved data.
8. **Corrective Action:** As required
9. **Time Required:** 1 to 4 hours per attach point
10. **Payments:** None

Comparison Bushings			
Quest Bushing # (Land Plane)		Aerocet Bushing (Amphibian)	
Number	Size	Number	Size
100-420-1109	2.063 ± 0.003 in	66-12112	2.063 ± 0.003 in
100-420-1110	2.125 ± 0.003 in	66-12113	2.125 ± 0.003 in

1. Use 66-12112 or 66-12113 in accordance with Quest Aircraft Field Service Instruction (FSI) 143. Use Aerocet number(s) when Aerocet floats are installed.
2. For aircraft modified with Aerocet™ floats (installed), use Aerocet bushings listed in table above instead of Quest Aircraft bushings.

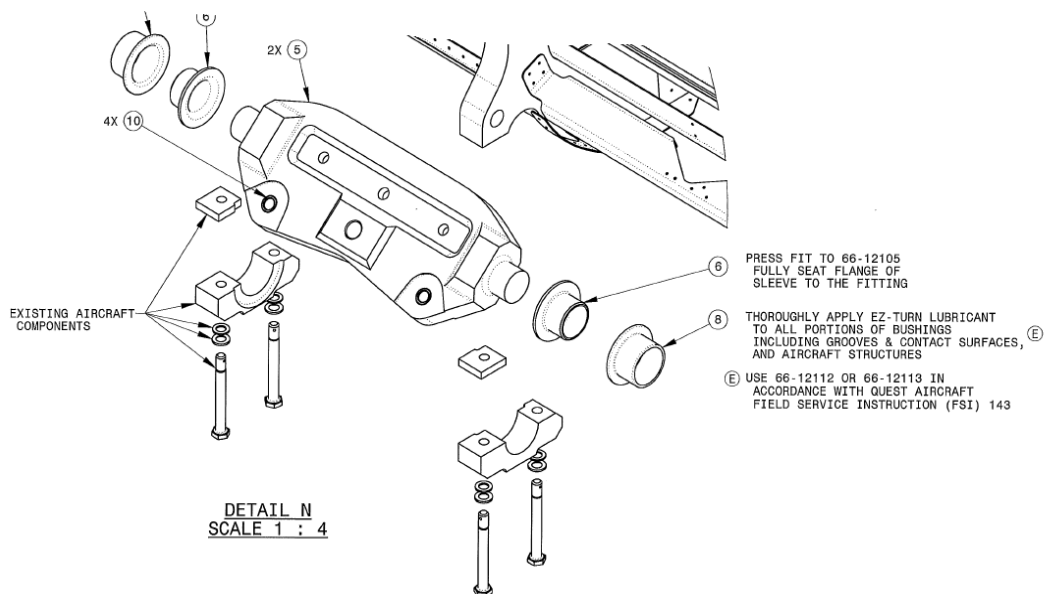

REVISION RECORD

Rev	Date	Summary of Change	Authorized by
I/R	02/10/2017	Initial Release	LM
A	03/17/2020	Added revision record	LM