

SERVICE LETTER SL43 66-12102

1. Release Date: 07/06/2018
2. Service Letter No.: SL43 66-12102
3. Subject: Fuselage Fittings
4. Part/Assembly No.: 66-12102-2
5. Float Model Affected: 6650 and 6750
6. Compliance: Mandatory Recommended Optional
7. Approval: All information provided is in accordance with approved data.
8. Corrective Action: Non-required.
9. Time Required: 2 hours per side plus 1 hour per each hold drilled (4 to 6 hours total depending on need to drill holes in strut).
10. Payments: Credit to Customer Under Warranty Customer Pays

NOTES:

This option is designed to offer additional strength within the front strut configuration for aircraft loads being encountered that are outside the scope of the FAA design requirements.

This option may not prevent additional issues from occurring within the configuration should the operating procedures or conditions encountered be outside the scope of the FAA design requirements.

66-12102-1 FUSELAGE FITTING, FWD

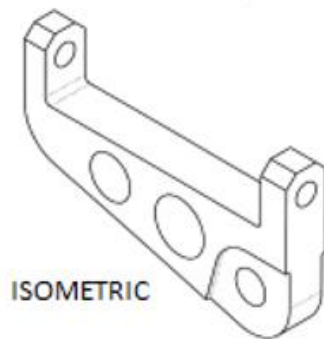

66-12102-2 FUSELAGE FITTING, FWD

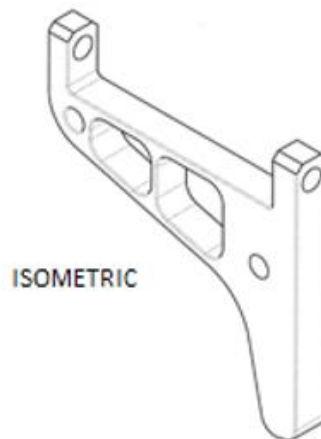

Figure 1 - Isometric Views of Fuselage Fittings

Option 1: 66-12102-1 Existing Aluminum Fitting

- Use existing fitting with existing strut
- Can be used with 66-12120 STRUT ASSEMBLY **OR** 66-12126 RIBBED STRUT

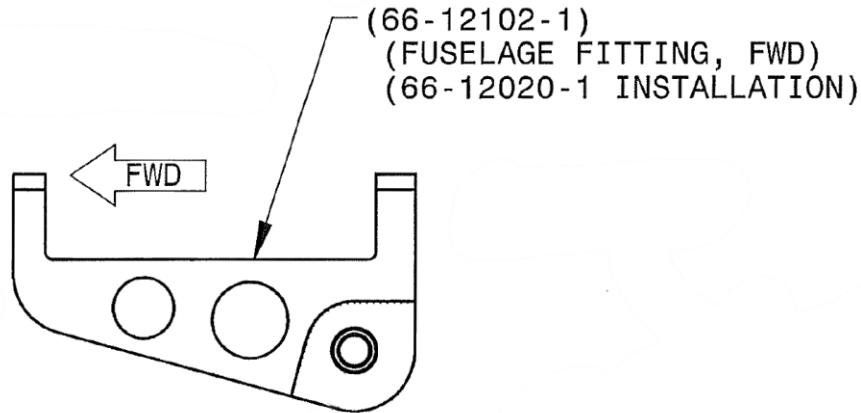

Figure 2 - Reference view of 66-12102-1

Option 2: 66-12102-2 Corrosion Resistant Steel

- 66-12102-2 FWD FUSELAGE FITTING [stainless] cannot be used with 66-12120 struts.
- Existing 66-12126 struts that are in the field will require the additional ¼" drilled bolt hole (IF none existing) to install AN4-23A bolt added. This will begin to be available in new struts aft 7/18. (reference figure below for location of ¼" drilled hole)
- Apply chemical conversion coating to bare aluminum (on inside of drilled hole if required). Recommend use of Henkel's Bonderite M-CR 1132 (Alodine 1132) Touch N-Prep Pen. (Paint will not likely allow fastener clearance, so is not required inside the hole.)
- NAS1149DxxxJ washers may be used interchangeably with NAS1149DxxxxK.
- Refer to S.L. 40 66-12127 for the recommended installation of 66-12127 Eyebolt if this is not already accomplished.

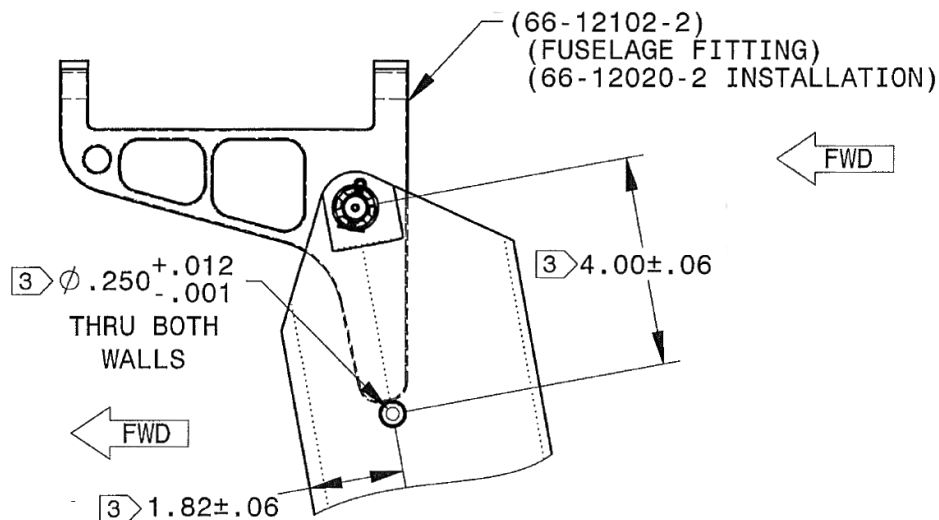

Figure 3 - Reference view of 66-12102-2

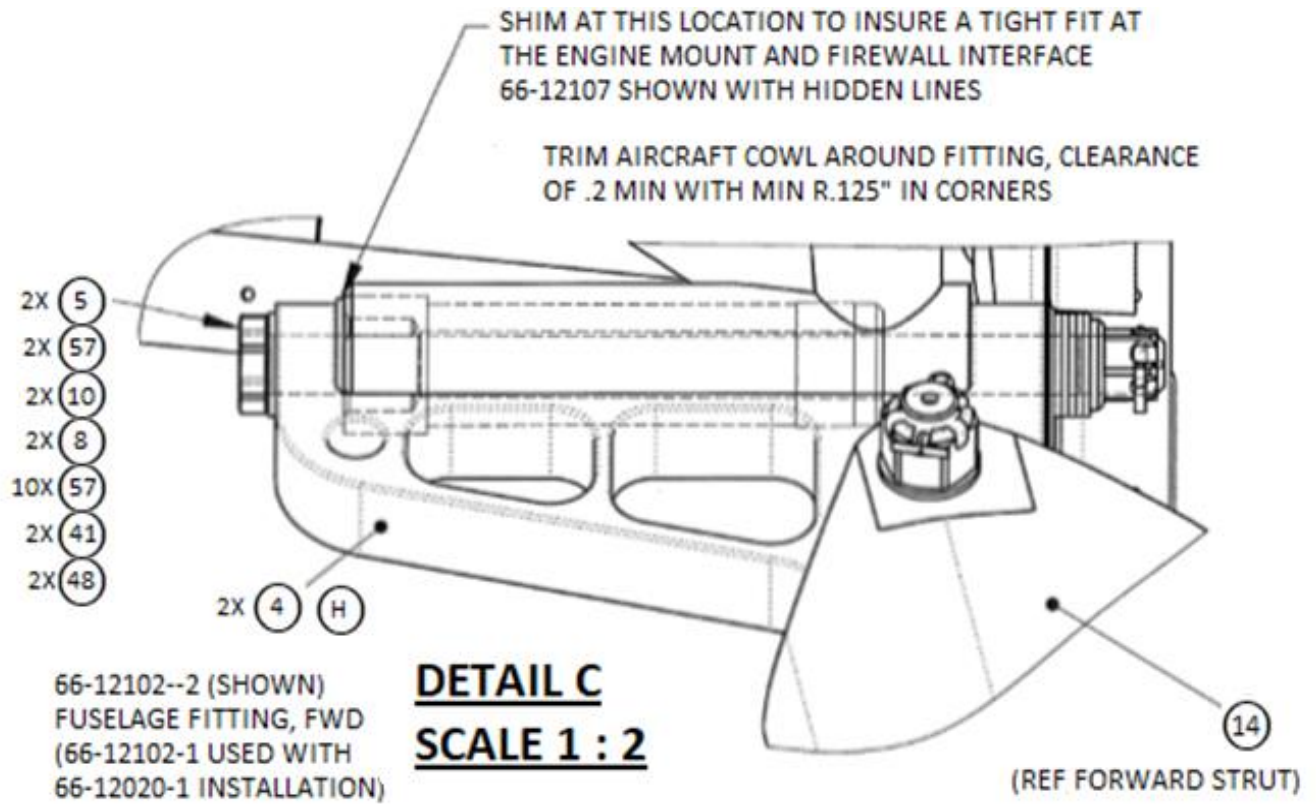

Figure 4 – 66-12102-2 Fuselage Fitting Detail Installation

Additional Details

The fuselage fittings will be just below 3.5 pounds heavier (3.448 lb) at 1.977 AHEAD of the firewall (Station -1.977). The workup is as follows:

Number	QTY	Pound	Weight	Fuselage Station	Moment
66-12102-1	2	1.032	2.064	-2.951	-6.090864
66-12102-2	2	2.756	5.512	-1.977	10.897224
Difference			3.448	-1.394	-4.80636

TABLE 1 STRUT AND FITTING INTERCHANGES		
STRUT	FWD FUSELAGE FITTING	NOTES
66-12120	66-12102-1	
66-12126	66-12102-1	
	66-12102-2	NOTE 3 ON DRAWING

TABLE 2 PARTS KIT FOR 66-12102-2 CORROSION RESISTANT FUSELAGE FITTING					
ITEM NO.	QTY	TYPE	PART NUMBER	DESCRIPTION	COMMENTS ALTERNATIVES
4	2	PART	66-12102-2	FUSELAGE FITTING, FWD	REFERENCE TABLE 1 FOR ACCEPTABLE CONBINATIONS
32	2	HRDWR	AN4-23A	BOLT – MACHINE, AIRCRAFT	IF DRILLED HOLE NEEDED
45	2	HRDWR	MS21044N4	NUT, SELF-LOCKING, REGULAR HIEGHT	(NEW)
48	2	HRDWR	MS24665-300	COTTER PIN	
52	2	HRDWR	NAS1149D0416K	WASHER, FLAT	(NEW)
53	2	HRDWR	NAS1149D0463K	WASHER, FLAT	(NEW)

NOTE: The following parts can be reused and are not a part of the service letter kit. If you choose to order new parts to replace these, please call our parts department.

TABLE 3 Reusable Parts					
ITEM NO.	QTY	TYPE	PART NUMBER	DESCRIPTION	COMMENTS ALTERNATIVES
2	2	PART	66-12126	STRUT, FWD	DRILL Ø.25 HOLE PER DTL IF REQ'D. NEW STRUTS WILL BEGIN TO HAVE THIS HOLE AFTER 7/18.
5	2	PART	66-12103	BOLT, CLOSE TOLERANCE	(REUSE EXISTING)
8	2	PART	66-12107	SPACER, FWD FUSELAGE FITTING	(REUSE EXISTING)
10	2	PART	66-12111-063	SHIM, FWD FUSELAGE	(REUSE EXISTING) ALT. USE -020, -032, -.040 OR NAS1149D08XX WASHERS AS NECESSARY TO ASSURE A TIGHT FIT
41	2	HRDWR	MS14144-8	NUT, SELF-LOCKING, LIGHTWEIGHT, CASTELLATED	(REUSE EXISTING)
57	10	HRDWR	NAS1149D0863K	WASHER, FLAT	(REUSE EXISTING)

Revisions

Rev	Date	Page	Summary of Change	Authorized by
I/R	07/06/2018	All	Initial Release	LM

-END-