



SERVICE LETTER SL42 56-10113 Rev A

Release Date: 05/22/2018

Service Letter No.: SL42 56-10113

Subject: Replacement of existing aluminum hinges with newer, stainless hinges.

Part/Assembly No.: 56-10113-SUPP

Float Model Affected: 5850

Corrective Action: Non-required.

Compliance: **Mandatory** **Recommended** **Optional**

Approval: All information provided is in accordance with approved data.

Cost to Customer: Credited No Charge Charged Warranty

Time Required: Allow 2 hours per door for installation.

NOTES:

1. For all illustrations in this service letter refer to Drawing 56-10113 – SUPP.
2. Aerocet recommends one of two methods to accomplish the replacement of hinges:
 - a) Method 1: Reusing the existing door assemblies, replacing only the hinge.
 - b) Method 2: If available for purchase, replacing the entire door assembly. If using this method, then refer to Aerocet Drawing 56-10113- SUPP, Sheets 1, & 3 for installation.) Method 2 is made to order. Please contact Parts Department (208) 448-0400 for availability and lead times.
3. Instructions are organized for clarity into recommended major steps: Step 1, Step 2, etc.
4. Refer to A-10034 §3 (**Maintenance Manual and Instructions for Continued Airworthiness for Aerocet Model 5850 Twin Seaplane Floats Installed on a De Havilland DHC-2 Beaver Airplane** for all resin and cloth work. Observe all safety measures and use appropriate safety equipment. Fastener torque values are provided in §1.4.

STEP 1: PREPARATION

IMPORTANT: Door assembly latch pin must align with the slot in the catch, or it will not properly close. Alignment marking at this step is intended to assure this alignment.

- 1.1 Method 1: Mark door and float deck with a visible line, such as fine felt-tipped pen, which will re-locate the door in later steps. See Drawing 56-10113-SUPP Sheet 1.

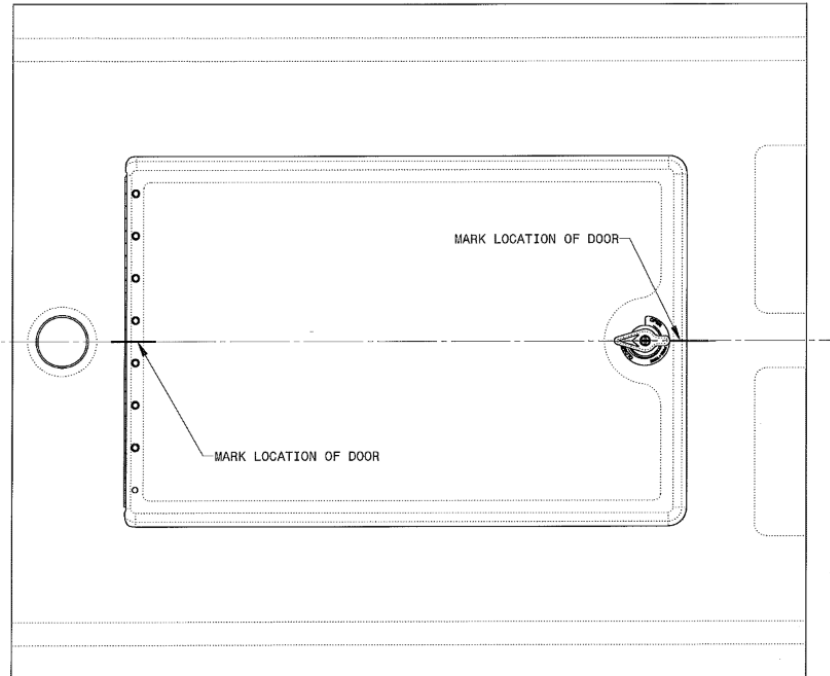

- 1.2 Remove existing door assembly by removing hinge pin. Proceed to Step 2.
- 1.3 Method 2: Locate and mark the centerline for the float deck opening, and the centerline of the new door assembly, fore and aft with a fine, felt-tipped pen.

Remove existing door assembly by removing the hinge pin. The illustration below can be seen on Drawing 56-10113-SUPP Sheet 2. Proceed to Step 2.

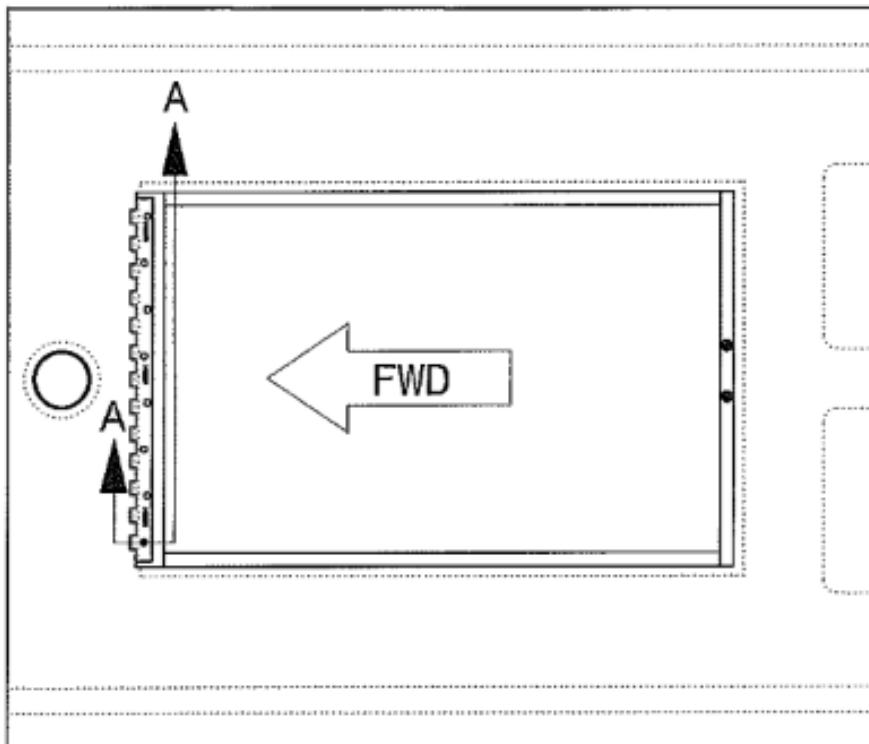

STEP 2: REMOVAL AND REPLACEMENT OF HINGE HALVES

NOTE: Method 1 applies to both hull and door hinge halves. Method 2 applies only to hull hinge half.

- 2.1 Use a center punch to create a divot in rivet heads, locating the center of each rivet head to be drilled for removal. The illustration below shows hull side hinge half. See Drawing 56-10113-SUPP Sheet 2.

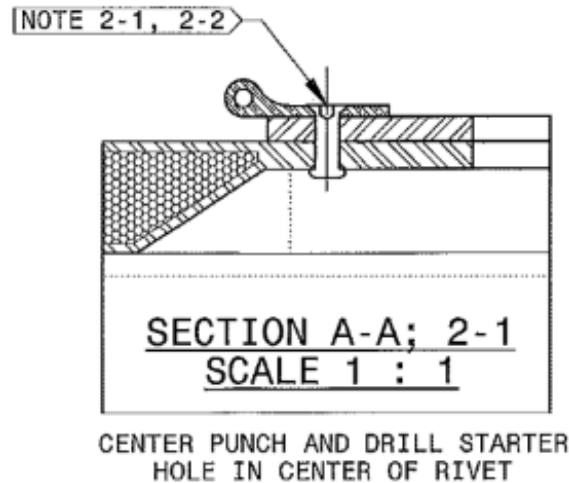

- 2.2 Pilot drill rivet heads with #50 drill, then drill #30 ($\varnothing.1285$) just to a depth that will allow it to be removed with a blunt punch. (Typically, $\varnothing.125$ " is inserted into the #30 hole, and pried side to side to remove the head.) The illustration below shows hull side hinge half. See Drawing 56-10113-SUPP Sheet 2.

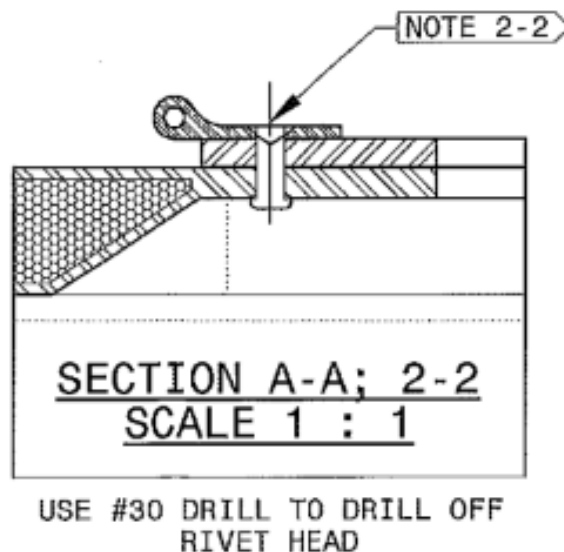

CAUTION: Avoid drilling too deeply as this may cause unnecessary damage to the door.

- 2.3 Remove tails of rivets, using a punch or pliers if necessary to tap or pull it.
- 2.4 Original hinges may be bonded to door assembly or float hull, so use a scraper, a knife or a razor to sever the adhesive bond and remove the hinge from the door assembly.
- 2.5 Remove any remaining hinge adhesive, preparing it for the new hinge bond. Start with mechanical means, such as a scraper or light sanding, being careful not to damage gel coat outside bonding area. Clean door and hinge thoroughly with acetone, assuring bonding areas are free of dust, debris and contamination.

NOTE: Protect all alignment markings (Step 1) from acetone using masking tape if necessary.

STEP 3: INSTALLATION OF HINGE HALF, DOOR SIDE

NOTE: Method 1 only. Does not apply to Method 2.

- 3.1 Identify the new hinge half to be installed. Match the holes on the door which are reused, then separate it from the opposite half by removing the hinge pin. (Save these parts for remaining work.) With hinge half bond-side up, apply a bead of sealant (Sika-flex 292i or equivalent), approximately $\varnothing 1/16''$ as shown, around hinge half periphery and between holes. Illustrations below refer to Drawing 56-10113-SUPP Sheet 3.

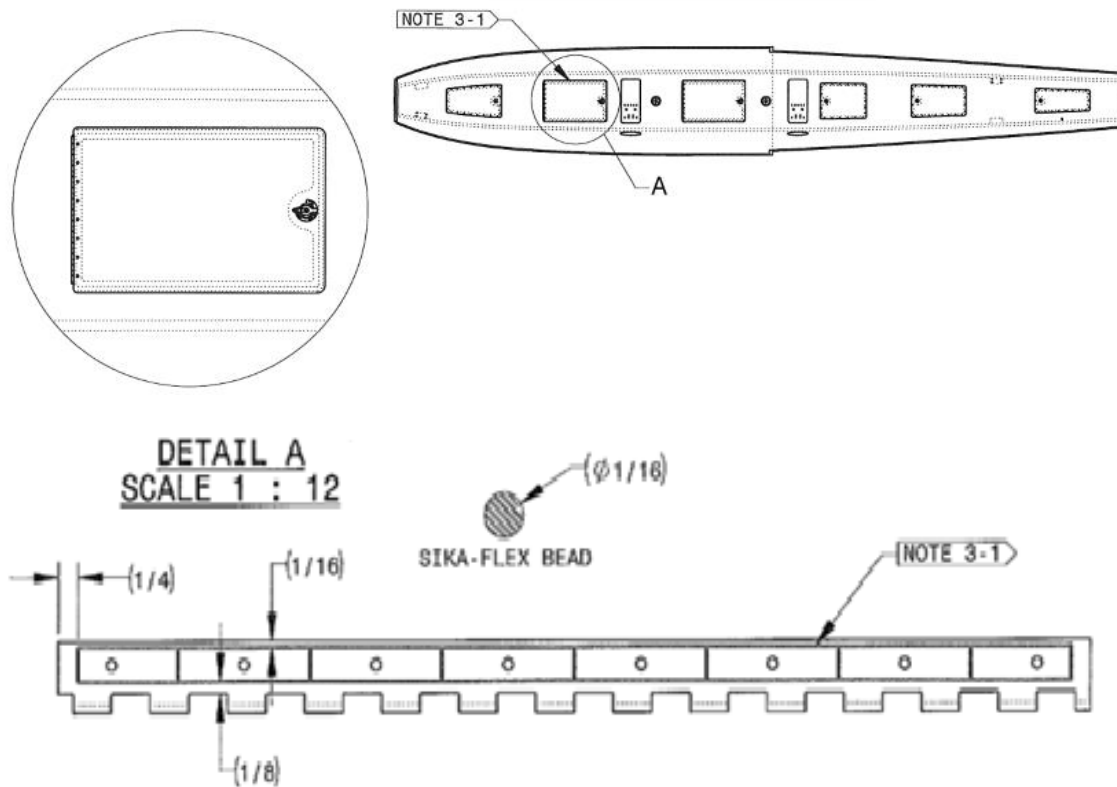

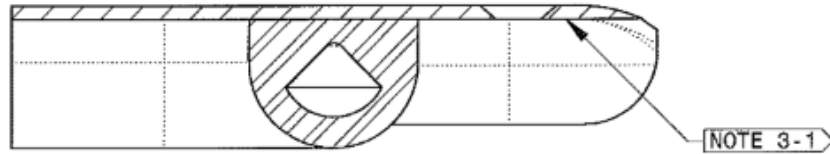

NOTE: The hinge halves are unique, fitting either the door side or the hull side. Hinge half on the hull side has a staggered hole placement and counter-sunk holes, while door assembly hinge half is all in line, and matches existing door assembly rivet holes.

NOTE: Avoid applying sealant too near or within rivet holes as this will foul clecos and will create undue mess.

- 3.2 Locate and temporarily install hinge half to the door using several clecos, evenly spaced. Illustration below refer to Drawing 56-10113-SUPP Sheet 3.

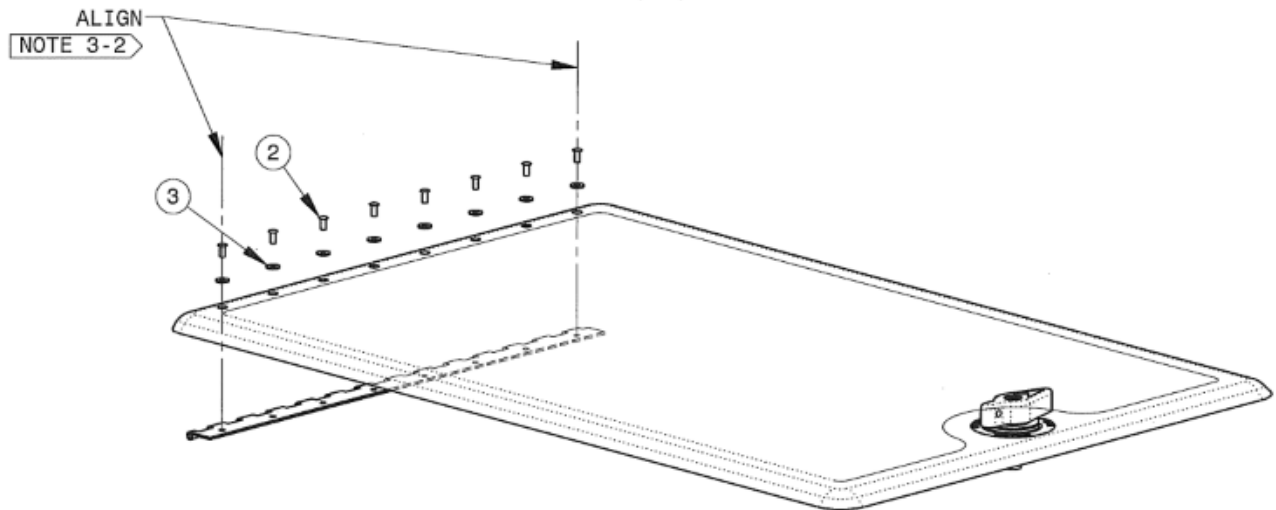

NOTE: The illustrations show the holes for the door but the same applies to the holes for the deck.

- 3.3 Apply sealant into open counter-sunk holes of door assembly (See Drawing 56-10113-SUPP for details). This will serve to seal beneath the rivet and washer next installed.

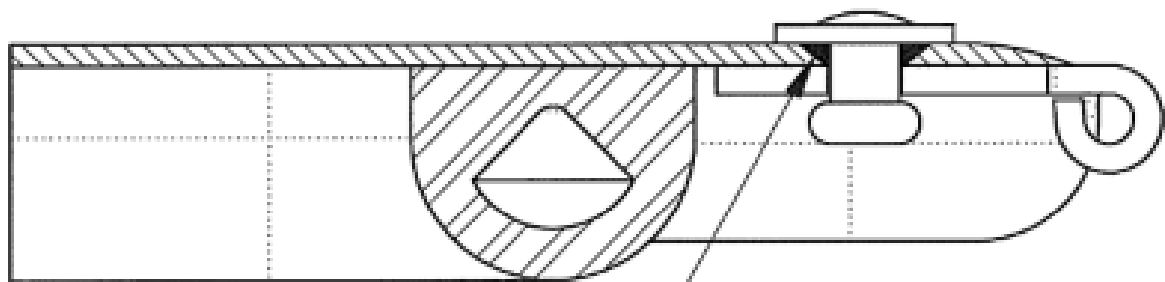

FILL WITH SIKAFLEX 292I

NOTE 3-3

- 3.4 Install MS16353 rivets with NAS1149CN416R washers beneath heads.

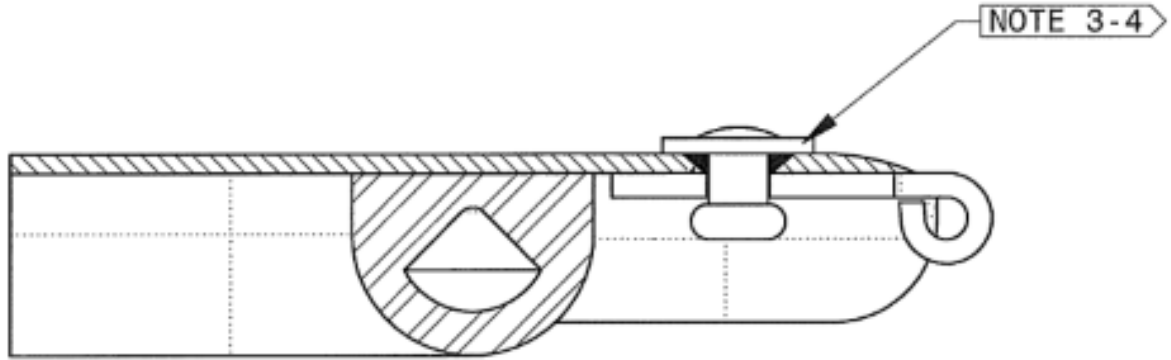

- 3.5 Remove clecos and install remaining rivets and washers.
- 3.6 Allow adequate sealant cure time. (Sika Flex 292i) is about 12 hours cure time. (Work can continue in other areas.) Excess sealant may be removed using a knife after initial cure time.

This completes the installation of the hinge half to the door assembly.

STEP 4: REPLACEMENT OF HINGE HALF, HULL ASSEMBLY SIDE, METHODS 1 & 2

- 4.1 With hinge assembled (one half already installed to the door assembly), locate door assembly in place temporarily, assuring that all previously established marks are acceptably aligned. (Marks on door assembly are aligned to marks on hull.) Illustration below refer to Drawing 56-10113-SUPP Sheet 4.

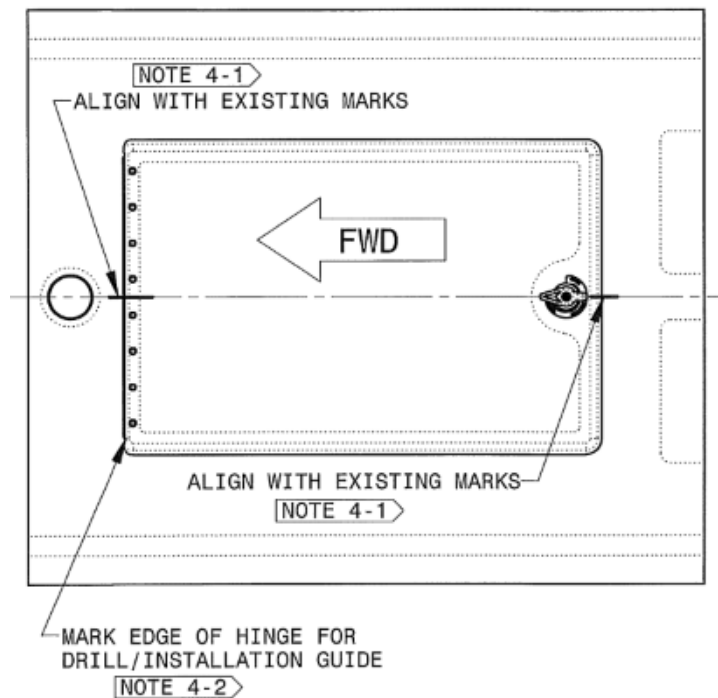

- 4.2 Mark the location of either the inboard or outboard edges of the hinge with a fine, felt-tipped pen.
- 4.3 Locate Aerocet drill fixture 65-T17520-supp with the heel of the fixture against the FWS edge of the locker opening stand-off. Locate the inboard or outboard edge of the drill fixture with the mark made in step 4-2. Illustration below refer to Drawing 56-10113-SUPP Sheet 4.

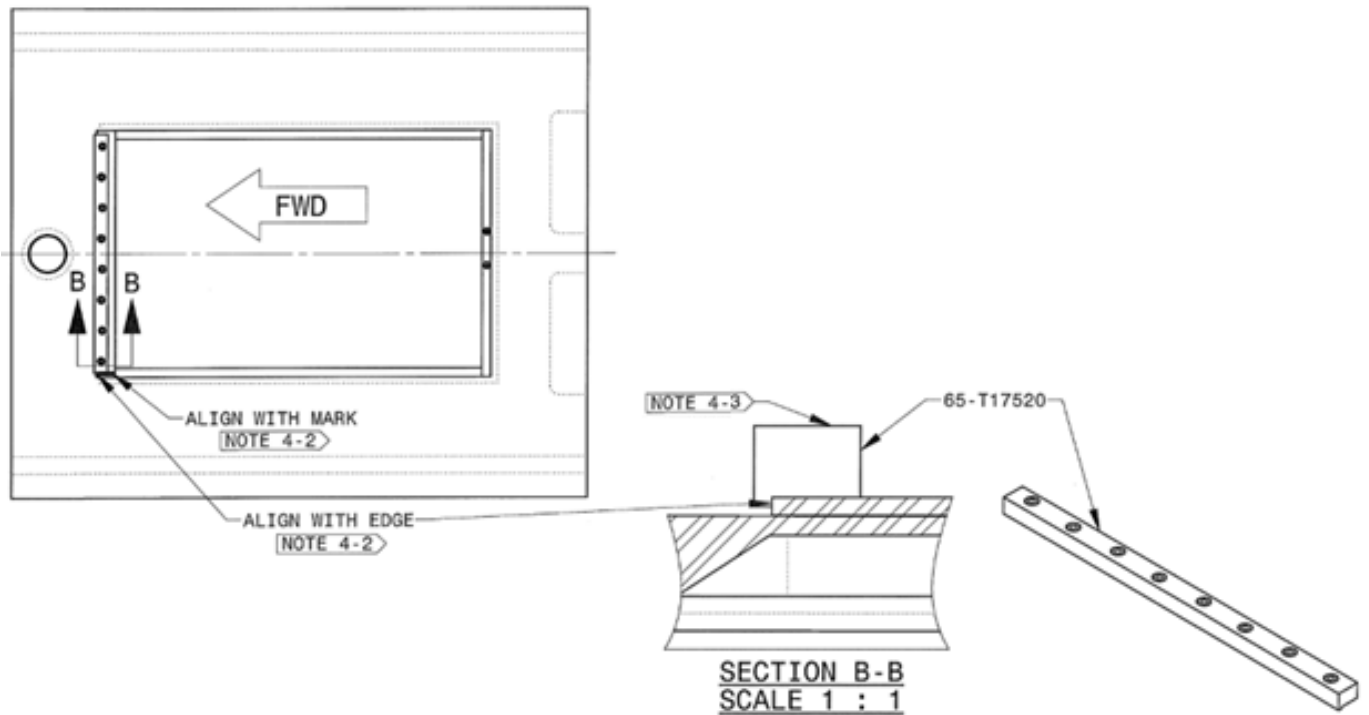

- 4.4 Clamp this fixture firmly in place with several C-clamps or other suitable means. Leave adequate space for drill to pass without striking clamps and moving the fixture during drilling.
- 4.5 With fixture secured, drill all holes with #10 drill.
- 4.6 Remove fixture and clean the bonding areas of float hull and hinge of all dust and debris using acetone.
- 4.7 With the hinge half bond size up, apply a bead of sealant, approximately $\varnothing 1/16''$ as shown, around periphery and between holes.
NOTE: Avoid applying sealant too near or within rivet holes as this will foul clecos and will create undue mess.
- 4.8 Install MS24694 machine screws, washers and nuts. Illustration below refer to Drawing 56-10113-SUPP Sheet 4.



- 4.9 Install hinge and locker door assembly with hinge pin, assuring proper function of the latch.
- 4.10 Allow for adequate sealant cure time. (12 hours for Sika Flex 292i). Excess sealant may be removed using a knife after initial cure time.

REQUIRED TOOLS:

- 1. Standard set of mechanic's hand tools, including wrenches, sockets and screw drivers
- 2. Work light (for use inside the float compartment).
- 3. Scraper, such as a gasket scraper or a knife for severing existing sealant.
- 4. 120 grit sandpaper
- 5. Fine, felt-tipped pen
- 6. 3/8" cordless or corded drill with #50, #30, & #10 drill bits.
- 7. Standard size caulking gun (for use with sealant application)
- 8. Rivet compression tool with proper semi-tubular rivet anvil



PART KIT FOR ONE LOCKER DOOR RETROFIT METHOD 1 – REPLACE HINGE ONLY

Item No.	Qty	TYPE	PART NUMBER	DESCRIPTION
1	1	ASSY	65-16515	LOCKER HINGE ASSEMBLY, 13 3/8
2	8	HRDWR	MS16535-177	RIVETS, SEMI-TUBULAR OVAL HEAD LENGTH A/R
3	8	HRDWR	NAS1149CN432R	WASHERS, FLAT, STAINLESS
4	8	HRDWR	MS24694C54	MACHINE SCREW, FLAT COLOUNTERSUNK HEAD, 100°
5	8	HRDWR	NAS1149C0316R	WASHER, FLAT, STAINLESS
6	8	HRDWR	MS21083C3	NUT, SELF-LOCKING, LOW HEIGHT, STAINLESS

Drawing included: 56-10113-SUPP

NOTE: A drill fixture (65-T17520) is required and available upon request by calling Aerocet Parts (208) 448-0400. Only one drill fixture is required, regardless of the number of kits you require.

PART KIT FOR ONE LOCKER DOOR RETROFIT METHOD 2 – REPLACE ENTIRE DOOR ASSEMBLY

Item No.	Qty	TYPE	PART NUMBER	DESCRIPTION
1	8	HRDWR	MS24694C54	MACHINE SCREW, FLAT COLOUNTERSUNK HEAD, 100°
2	8	HRDWR	NAS1149C0316R	WASHER, FLAT, STAINLESS
3	8	HRDWR	MS21083C3	NUT, SELF-LOCKING, LOW HEIGHT, STAINLESS
4	1	ASSY	65-16510	LOCKER DOOR ASSEMBLY

Drawing included: 56-10113 – SUPP

NOTE: A drill fixture (65-T17520) is required and available upon request by calling Aerocet Parts (208) 448-0400. Only one drill fixture is required, regardless of the number of kits you require.

Revisions

Rev	Date	Page	Summary of Change	Authorized by
I/R	05/22/2018	All	Initial Release	LM
A	02/07/2019	9	Changed item #4 in Part Kit for Method 2 to 65-16510 instead of 65-17510	LM

-END-