



SERVICE LETTER SL41 66-12520 Rev E

- 1. **Release Date:** 11/06/2018
- 2. **Service Letter No.:** SL41 66-12520 Rev D
- 3. **Subject:** Firewall Reinforcement Optional Installation
- 4. **Part/Assembly No.:** 66-12520
- 5. **Float Model Affected:** 6650 and 6750
- 6. **Compliance:** **Mandatory** **Recommended** **Optional**

NOTE: Recommended upgrade for those operating in open sea conditions

- 7. **Approval:** All information provided is in accordance with approved data.
- 8. **Corrective Action:** Non-required.
- 9. **Time Required: Approximately 40 Hours**

Minimum Persons: 1 person

Man-hour estimates are based on the minimum personnel required. As appropriate, Aerocet encourages the use of additional personnel, which may reduce the actual man-hours. "Minimum Persons" refers only to maintenance personnel or installers, and unless otherwise specified within this instruction does not include additional personnel who may be needed solely to comply with safety requirements (for example, safety observers who are not performing tasks within this instruction). It is the responsibility of maintenance personnel to comply with safety requirements, including having a safety observer available as needed.

- 10. **Payments:** Credit to Customer Under Warranty Customer Pays

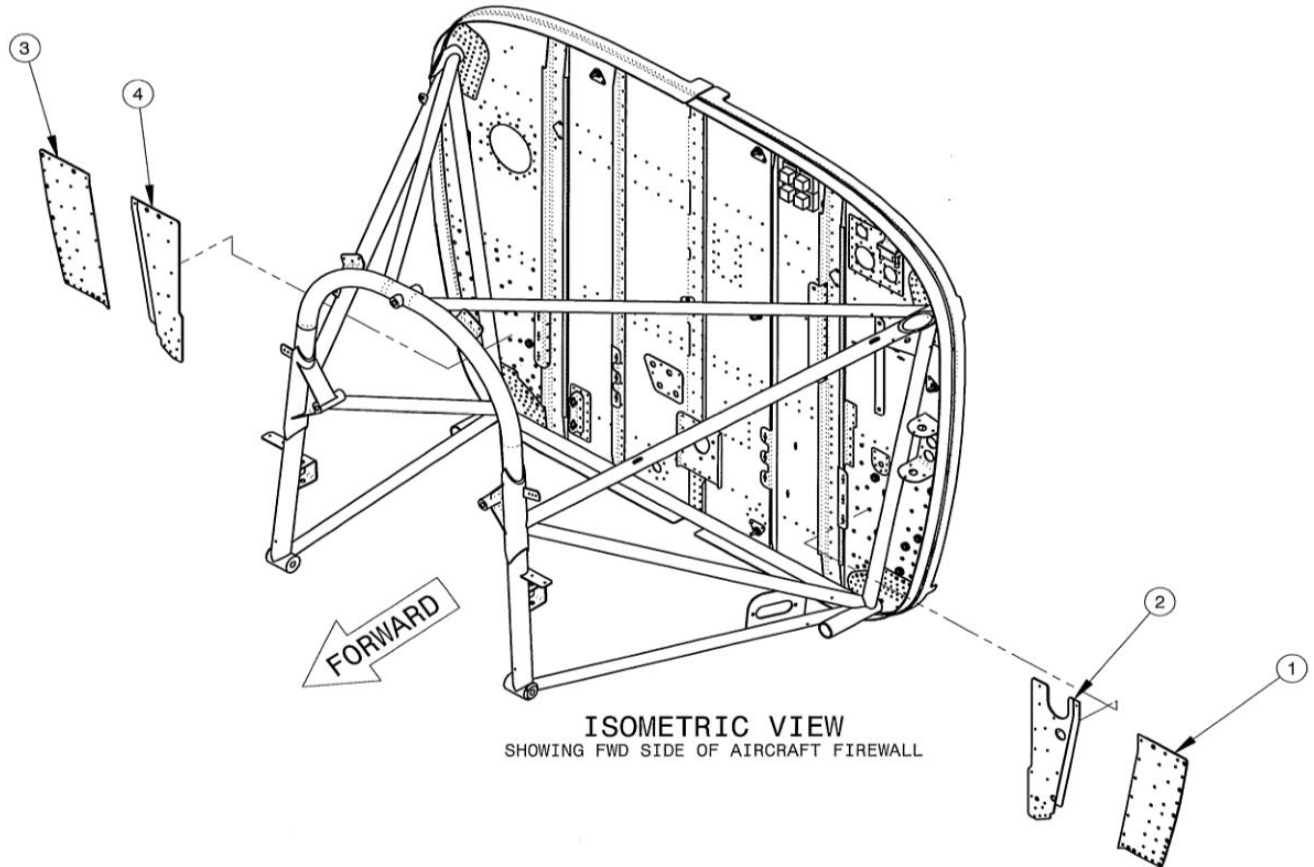

NOTES:

1. 66-12520 installation of firewall reinforcements is optional for use with Aerocet Model 6650 or 6750 float installations on Quest Kodiak 100 Aircraft. This drawing is intended to show the acceptable installation of Aerocet firewall reinforcements to FWD side of Kodiak firewall.
2. Optional: In areas of high potential for salt water corrosion, apply primer in accordance with Aerocet process specification A-31008, or apply PPG Aerospace, PRC-DeSoto Koropon®515K011 Fluid Resistant Primer per manufacturer’s instructions.
3. Because working time is limited, about 30 minutes, consideration should be made for staging the work needed, such that preparation, application and installation can be accomplished within those times.
4. Do not use lubricants that contain silicones, molybdenum disulfide, or graphite in any drilling or fastener installation.
5. Remove firewall insulation blanket, if applicable. Save all hardware for re-use.
6. **Note 5:** Remove any existing sealant from rivet(s) where indicated, taking care not to damage substrate. Sealant removal and application is accomplished with purpose built plastic spatulas and scrapers. Do not use metal devices which will damage components.
7. **Note 6:** Remove existing rivet(s) where indicated, and all firewall insulation blanket snaps that are located within the reinforcement installation area. (Recommend use of cobalt or

similar drill when removing MONEL or similar grade rivets.) Use low speed drill settings and/or lubricant (Ref Note 3) to avoid over-heating.

- a. Suggest initial pilot drill (#40 or 41) of rivet head. Drill rivet head only (#30 for -4 stock sized rivet), remove head, and carefully remove rivet shank and tail. Do not pry beneath rivet head.
- b. De-burr hole and remove all debris.
- c. Final hole size in accordance with Table 1.
- d. Mis-drilled reinforcement fasteners: Should nominal -4 hole size be exceeded, then drill for -5 rivet. Should nominal-5 hole size be exceeded, then drill for NAS9310M-5 oversize blind rivet.
- e. Mis-drilled insulation snap stud fasteners: Should nominal CR3523-4 hole size be exceeded, then drill for oversize CR3553-4. Should oversize CR3553-4 be exceeded, then drill for 05/32 hole, 0.169-0.175 and install snap in accordance with detail shown on sheet 4.

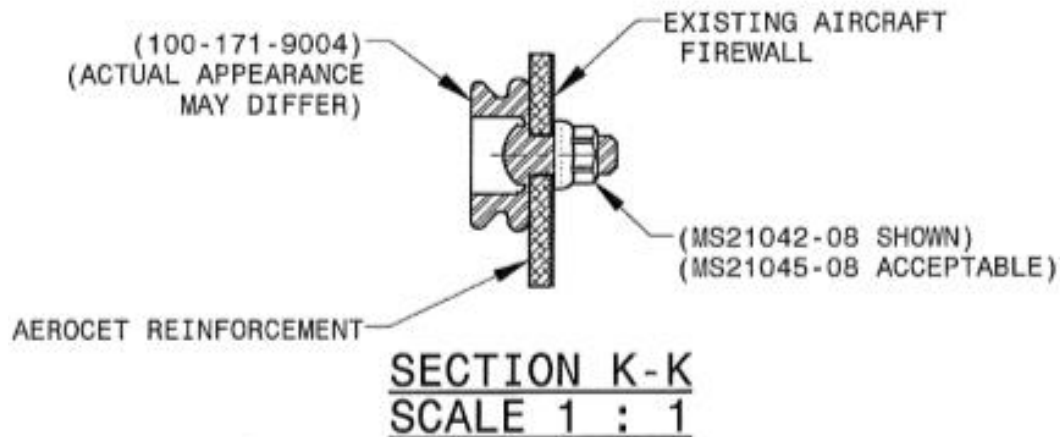

6 OVERSIZE HOLE FOR SNAP STUD RE-INSTALLATION SHOWING SNAP STUD EQUIPPED WITH #8 THREADED FASTENER REFERENCE TABLE 1 FOR ACCEPTABLE HOLE PREPARATION QUANTITIES ARE AS REQUIRED

8. **Note 7:** Temporarily install plates, aligning pre-drilled holes in plates to existing holes in firewall. Back-drill plates to match existing firewall rivet hole diameters, including those which fasten insulation snaps, if applicable. Final hole size in accordance with Table 1.
9. **Note 8:** Transfer remaining holes in plates to firewall, drill #30. Final hole size in accordance with Table 1.
10. Remove plates, deburr all holes in plates and firewall. Clean all surfaces to remove debris, oil and dirt. Use cleaning solvent such as PPG DESOCLEAN(R) 110, isopropyl alcohol or acetone and lint free cloths. Follow immediately with dry, lint free cloths to progressively remove all contaminates. Recommend use of clean, lint free gloves to prevent

contamination of bonding areas. Do not allow the solvent to dry on the surface as will allow contaminants to remain.

11. Apply PPG-148 primer to firewall bonding areas. Allow 30 minutes drying time, not exceeding 2 hours before applying sealant and installing reinforcements.
12. **Note 11:** Evenly apply sealant to underside of plates and affix in place. Recommend about .010" minimum sealant thickness. A small amount of sealant squeeze-out is required around all edges. This is subsequently faired to firewall surface.
13. Install rivets, reinforcements and firewall blanket snaps:
 - a. Assure proper size of rivets for diameter and length.
 - b. Install rivets within the working time of the sealant. Does not require "wet" installation; or,
 - c. If installing after sealant cure, then thoroughly clean hole(s) of all sealant. Install rivets "wet" by first dipping rivets in sealant.
14. **Note 13:** Preferably before the sealant has reached "tack free" condition, apply a fillet of sealant to all reinforcement seams.

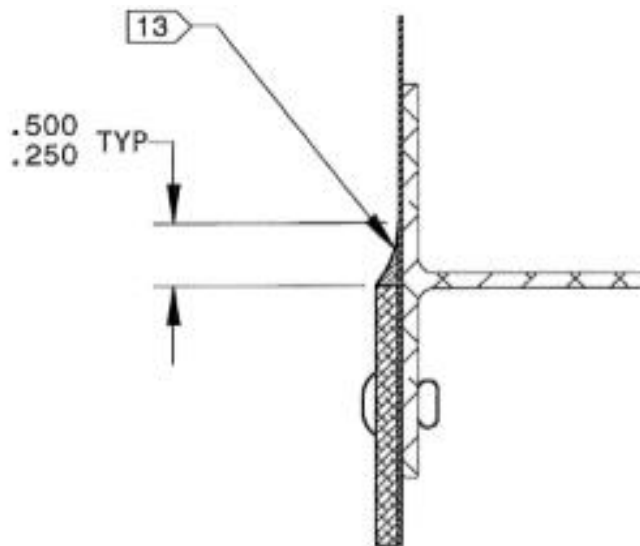

SECTION E-E
SCALE 1 : 1

SHOWING TYPICAL FILLET SEAL AROUND
ALL OPEN SEAMS OF AEROCET REINFORCEMENTS

15. Reinstall firewall insulation blanket and any other aircraft affected appliances or equipment in accordance with Quest Kodiak Aircraft Maintenance Manual AM902.0.



PARTS LIST for 66-12520 FIREWALL REINFORCEMENT

Item No.	QTY	Type	Part No.	Description	Alternate
1	1	PART	66-12521-L1	FIREWALL REINFORCEMENT, LHS OUTBOARD	
2	1	PART	66-12521-L2	FIREWALL REINFORCEMENT, LHS INBOARD	
3	1	PART	66-12521-R1	FIREWALL REINFORCEMENT, RHS OUTBOARD	
4	1	PART	66-12521-R2	FIREWALL REINFORCEMENT, RHS INBOARD	
5	16*	HRDWR	CR3523-4-02	CHERRYMAX RIVET, UNIVERSAL HEAD, LENGTH A/R	
6	75*	HRDWR	MS20615-4MP4	RIVET, SOLID, UNIVERSAL HEAD, MONEL, LENGTH A/R	MS20615-4M4R, MS20615-4MP5 OR MS20615-4M5
7	10*	HRDWR	MS20615-4MP5R	RIVET, SOLID, UNIVERSAL HEAD, MONEL, LENGTH A/R	MS20615-4M5R, MS20615-4MP6 OR MS20615-4M6
8	1	HRDWR	NAS1149C0463R	WASHER	

The following items are not included in the parts list. The “acceptable sealants” can be purchased from Aerocet but it may take 6 weeks for the products to arrive at Aerocet.

ACCEPTABLE SEALANTS

PRODUCT NO.	QTY	MANUFACTURER	COMMENTS
DAPCO 2200	2	CYTEC SOLVAY	TWO-PART SILICONE, APPROXIMATELY 30 MINUTES WORKING TIME
PPG PR-148	1	PPG PRC-Desoto	CLEANING SOLVENT, OR ALT. PER NOTES

OPTIONAL

PRODUCT NO:	QTY	MANUFACTURER	COMMENTS
PPG 515K011	1	PPG	FLUID RESISTANT PRIMER

EXPENDABLES

LINT FREE CLOTHS

TOOLS

TOOLS: STANDARD TOOLSET INCLUDING RIVET DRIVER, PUNCHES AND BUCKING BAR(S), BLIND RIVET PULLER, BOX END WRENCHES, RATCHET, SOCKETS, PLASTIC SCRAPERS, MASKING TAPE.

*Estimated quantities. May require more or less.

HAZMAT NOTES:

- There is a \$55.00 Aerocet handling fee on each order.
- If the order is for air shipping, the PR-148 and DAPCO 2200 are packed and shipped separately with a \$30 hazmat fee for each package.
- Some countries do not allow incoming hazmat shipments. Please verify this prior to ordering.

REV	Date	Page	Summary of Change	Authorized by
A	05/01/2018	All	Rivet changes—not released to public.	LM
B	05/08/2018	ALL	Released as Rev B with drawing changes	LM
C	07/19/2018	5	Added HAZMAT notes	LM
D	11/06/2018	1, 5	<ul style="list-style-type: none"> • Amount of time required to perform work • Split table for clarity of items included in parts list 	LM
E	02/24/2019	1, 6	<ul style="list-style-type: none"> • Corrected release date for Rev D • Updated Release date to REV E for Summary of Changes 	LM

-END-