

SERVICE LETTER SL31 66-12020 Rev A

1. **Release Date:** August 29, 2017
2. **Service Letter No.:** SL31 66-12020
3. **Reason for Change:** Dimensions between key areas of floats
4. **Part/Assembly No.:** Drawing 66-12020
5. **Float Model Affected:** 6650
6. **Disposition of Product in Field:** Informational Only
7. **Approval:** All information provided is in accordance with approved data.
8. **Corrective Action:** (Informational Only)
9. **Time Required:** N/A
10. **Payments:** N/A

Instructions:

1. There should be a minimum .2" opening around the fitting including the fuselage flange ahead of the firewall. See Figure 1 below.
2. There is some rotational movement on the front fitting. This gap should be opened to keep this from happening.
3. Any damage can be cleaned up as there is nothing structural in this area on the flange of metal or cowling.
4. Rotations for takeoff (VR1) should be no higher than 53 KIAS.
5. Landings should be as slow as possible keeping the nose of the floats as low as practical to cut waves encountered.
6. All takeoff and landings should be done perpendicular to the waves and not at an angle.
7. The flying wire length should be according to the drawings and no longer than 73.125". They are typically 73.0" and are definitely stretched if more than 73.125". (Reference Service Letter SL23-66-12020).
8. This measurement is of the "tie rod itself not including the clevis ends."

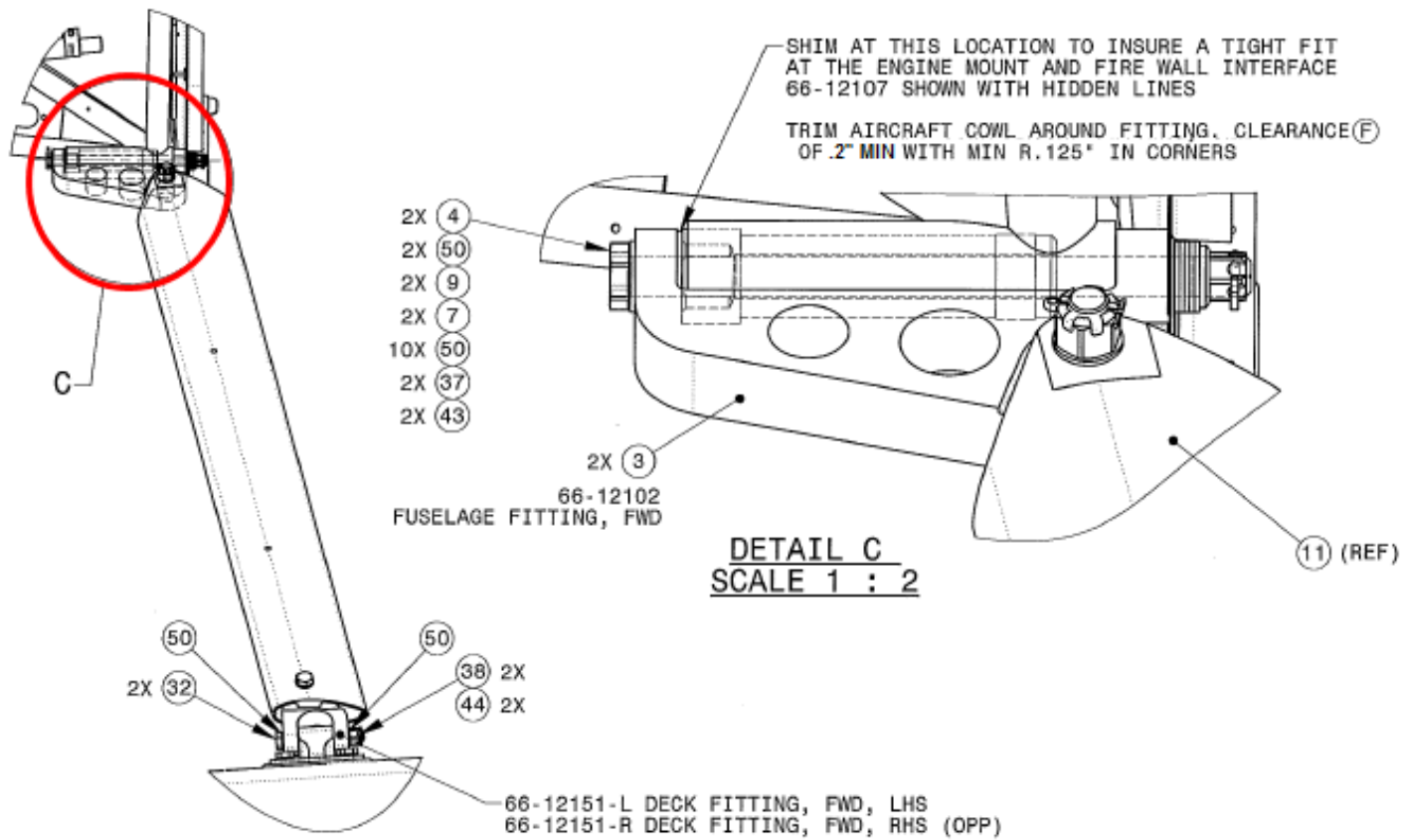

Figure 1: Shim Location 66-12020

REVISION RECORD

Rev	Date	Summary of Change	Authorized by
I/R	08/29/2017	Initial Release	LM
A	03/18/2020	Added Revision Record	LM