

SERVICE LETTER SL29 66-12700 Rev A

1. **Release Date:** 06/05/2017
2. **Service Letter No.:** SL29 66-12700
3. **Reason for Change:** Installer request to lengthen hydraulic lines to reach outside of the intercostal. Length increase for fit of 66-12731 hoses.
4. **Part/Assembly No.:** ECN 1161 Drawing 66-12700
5. **Float Model Affected:** 6650
6. **Disposition of Product in Field:** Optional (Required if Flexible Hoses Used).
7. **Approval:** All information provided is in accordance with approved data.
8. **Corrective Action:** Relocate the connection points of the internal lines closer to the intercostal of the aircraft where it is more accessible for mechanics.
9. **Time Required:** Under 4 hours
10. **Payments:** None. Call (208) 448-0400 FOR Parts Department.

Parts Kit				
Item No.	Quantity	Type	Part No.	Description
9	2	ASSY	66-12727	TUBE, HYDRAULIC, #17
20	1	ASSY	66-47163	TUBE, HYDRAULIC, #7
21	1	ASSY	66-47165	TUBE HYDRAULIC, #9
40	2	HRDWR	AS5174D0404	UNION, FLARED TUBE (AN815-4D, OBS.)

Instructions:

1. 66-12700: Add 66-12727 (2X) (Figure 1) and AS5174D0404 Unions (Figures 1 and 2) (2X) to RHS hydraulics exit.
2. 66-12727: New
3. 66-47163: Length 36.00 was 33.63.
4. 66-47165: Length 36.00 was 32.75
5. Verify length and/or replace existing 66-47163 and 66-47165 tube assemblies with Rev A, longer versions when changing 66-12731 flexible hose assemblies. (Ref Service Letter SL66-12700. Add 66-12727.

NOTE: Hydraulic lines may be constructed to suit installation in accordance with Aerocet Drawing No. 36-15430 and installed in accordance with A.C. 43.13-1. Hydraulic system length may not be increased. Number of Joints, bends and fittings may not be increased.

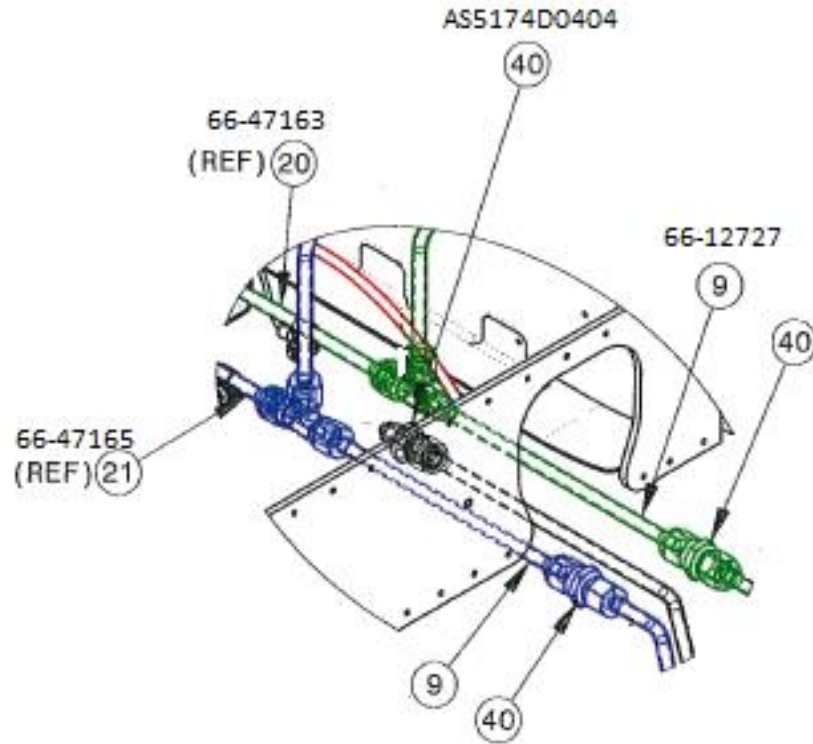

Figure 1: Hydraulic Tube # 17 (9) with Union, Flared Tube (40)

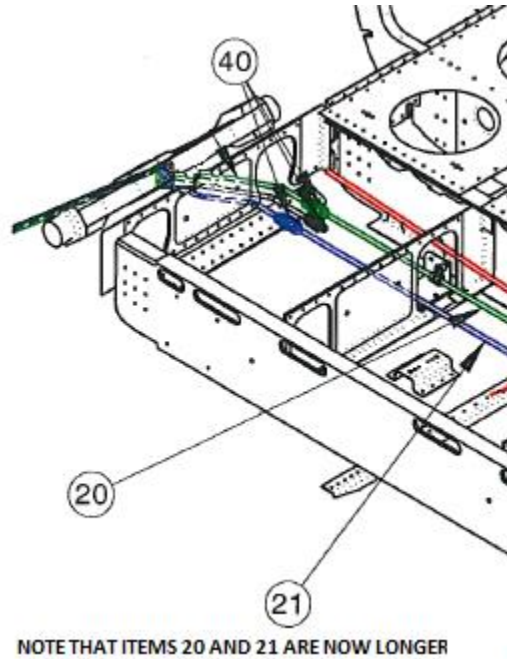

Figure 2: Longer Hydraulic Tubes (20 and 21)

REVISION RECORD

Rev	Date	Summary of Change	Authorized by
I/R	06/05/2017	Initial Release	LM
A	03/18/2020	<ul style="list-style-type: none">• Added release date• Added revision record	LM

-END-