

SERVICE LETTER SL21 66-47200 Rev A



Release Date: 02/01/2017

Service Letter #: SL21 66-47200

Part/Assembly #: 66-47200

Float Model Affected: Aerocet Model 6650 floats

Approval: All information provided is in accordance with approved data.

Affected: Hydraulic Pump Motor

Reason for Change: Premature gear wear

Corrective Action: Remove and replace hydraulic pump motor.

Time Required: 1 hour

R

Replacement Instructions:

1. Aerocet is sending to you part # 66-47200 which is the complete pedestal, hydraulic assembly so that you will not experience significant down time.
2. Recommend moving pilot seat full aft or removing altogether for easy access.
3. Remove cable from water rudder retract handle.

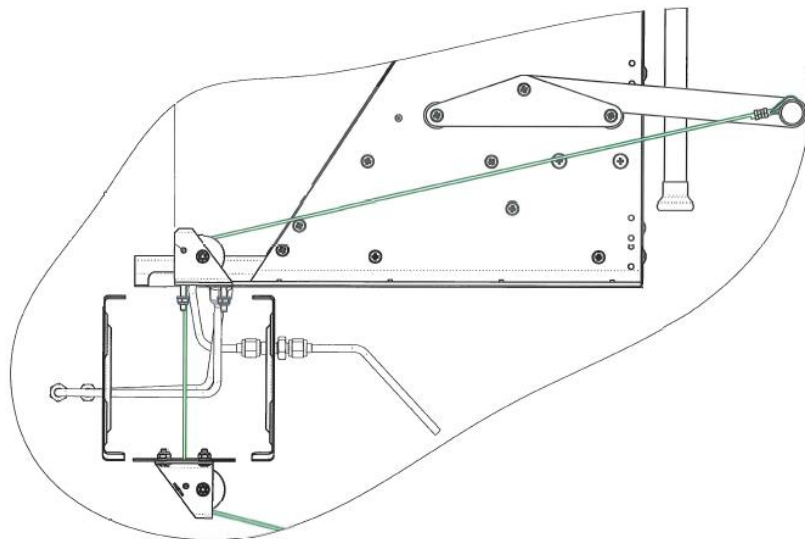

Caution: Weight of rudder will need to be lessened to ease removal.

4. Remove 3 screws from hydraulic shield.

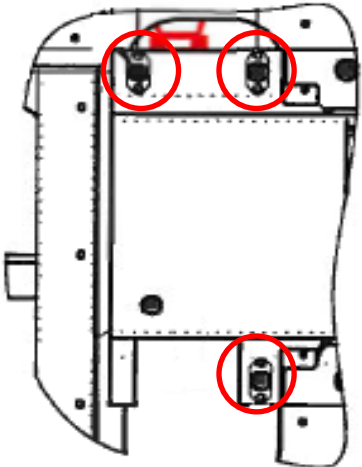

5. Remove 4 screws from pedestal base.

6. Disconnect 2 hydraulic lines and one drain line from front of pedestal. Cap and plug as necessary.

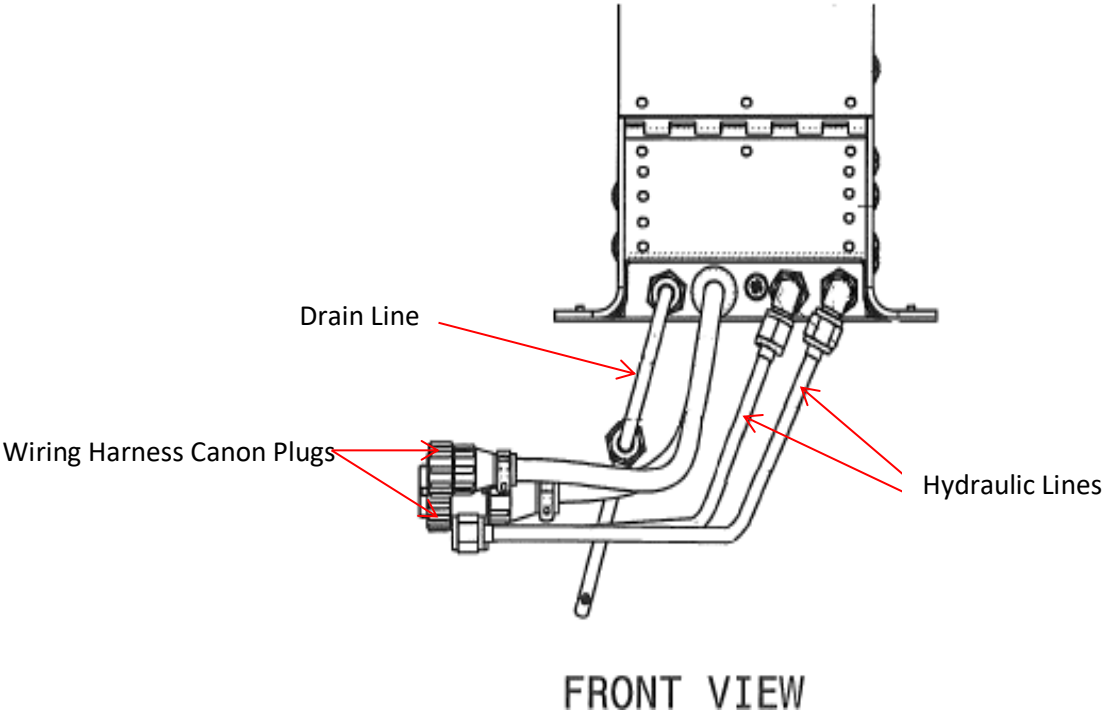

7. Under floor, disconnect two-wire harness canon plugs. (See above)
8. Remove pedestal from aircraft
9. Replace existing pedestal with supplied pedestal in same order as removal.
10. Call (208) 448-0400 for shipping voucher number and ship existing unit back to:

Aerocet, Inc.
 265 Shannon Drive
 Priest River, ID 83865

NOTE: You will be billed \$10, 170.00 for each unit that is not returned within 30 days of receipt of the new assembly.

REVISION RECORD

Rev	Date	Summary of Change	Authorized by
I/R	02/01/2017	Initial Release	LM
A	03/17/2020	<ul style="list-style-type: none"> • Added release date • Added revision record 	LM